

# CONDITION MONITORING AND DIAGNOSTICS OF SLIDING BEARINGS

Ranko Antunović, Nikola Vučetić, Eleonora Desnica, Imre Kiss

Sliding bearings (supports for shaft sleeves and shafts)

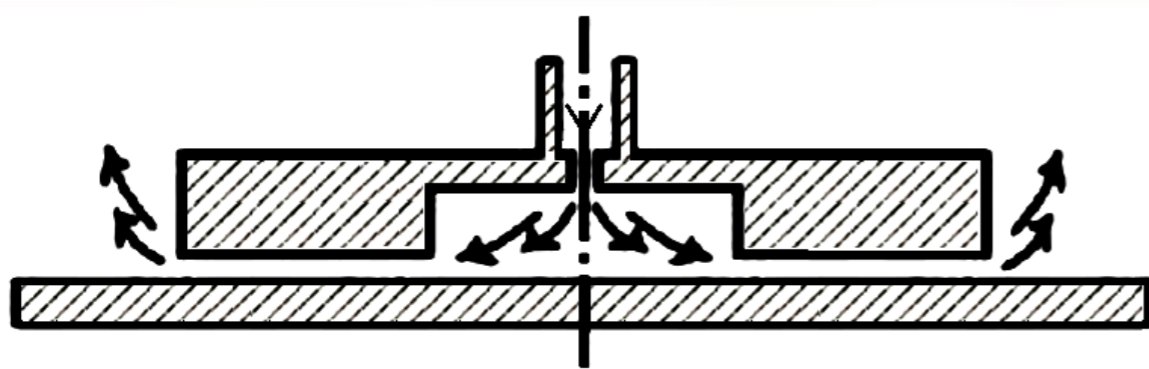

Case study

Damage to the surface of plain bearings

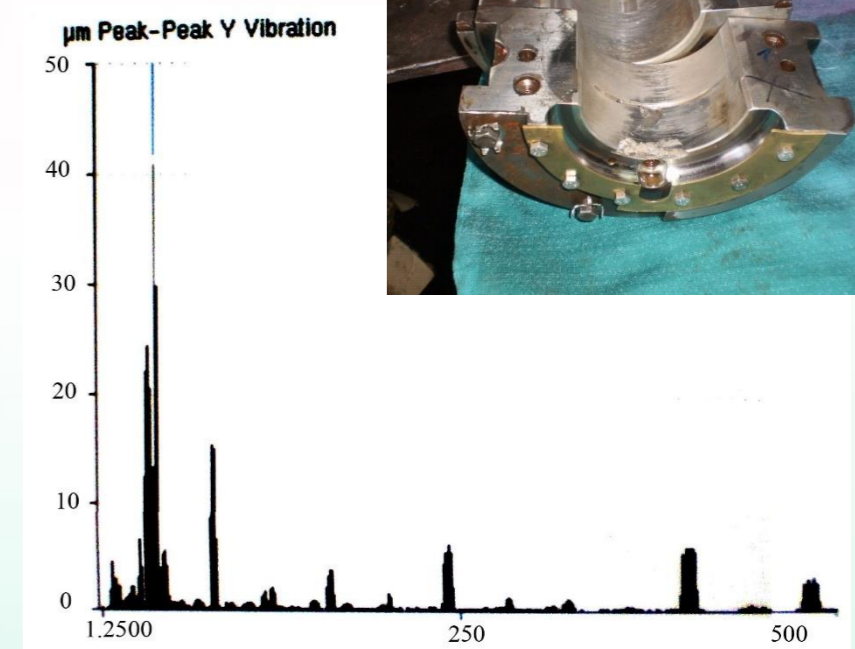
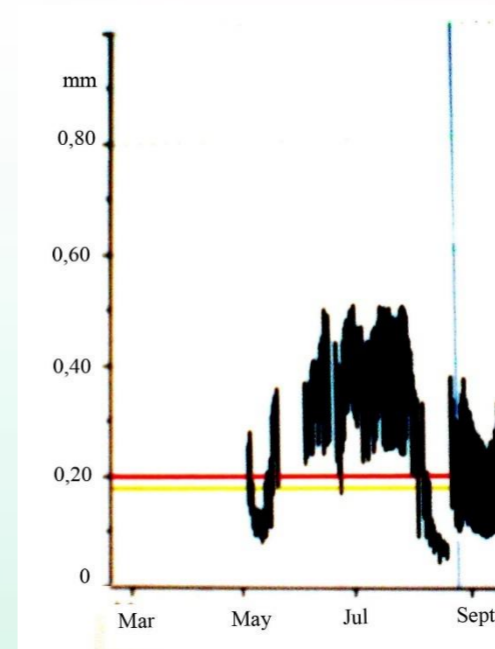
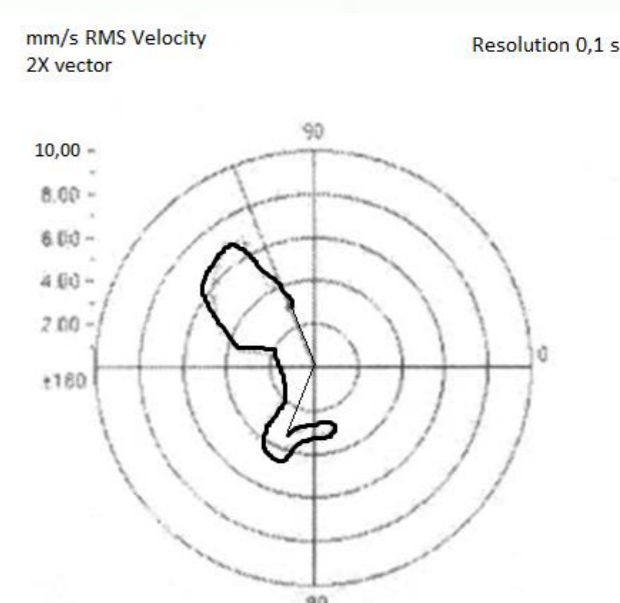
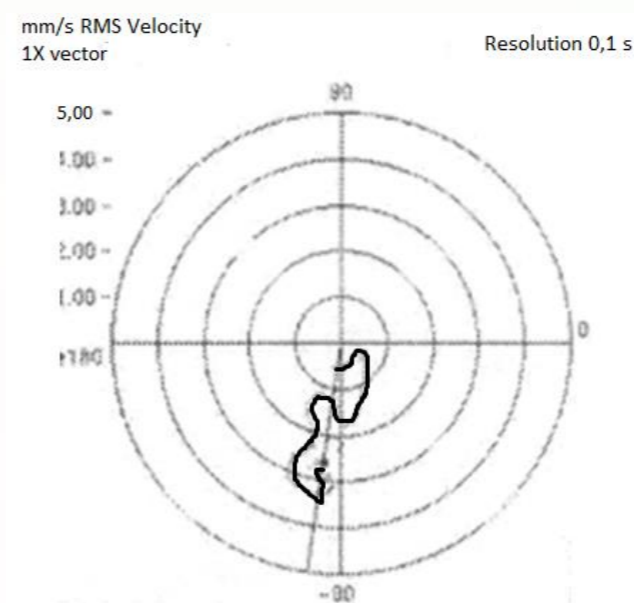
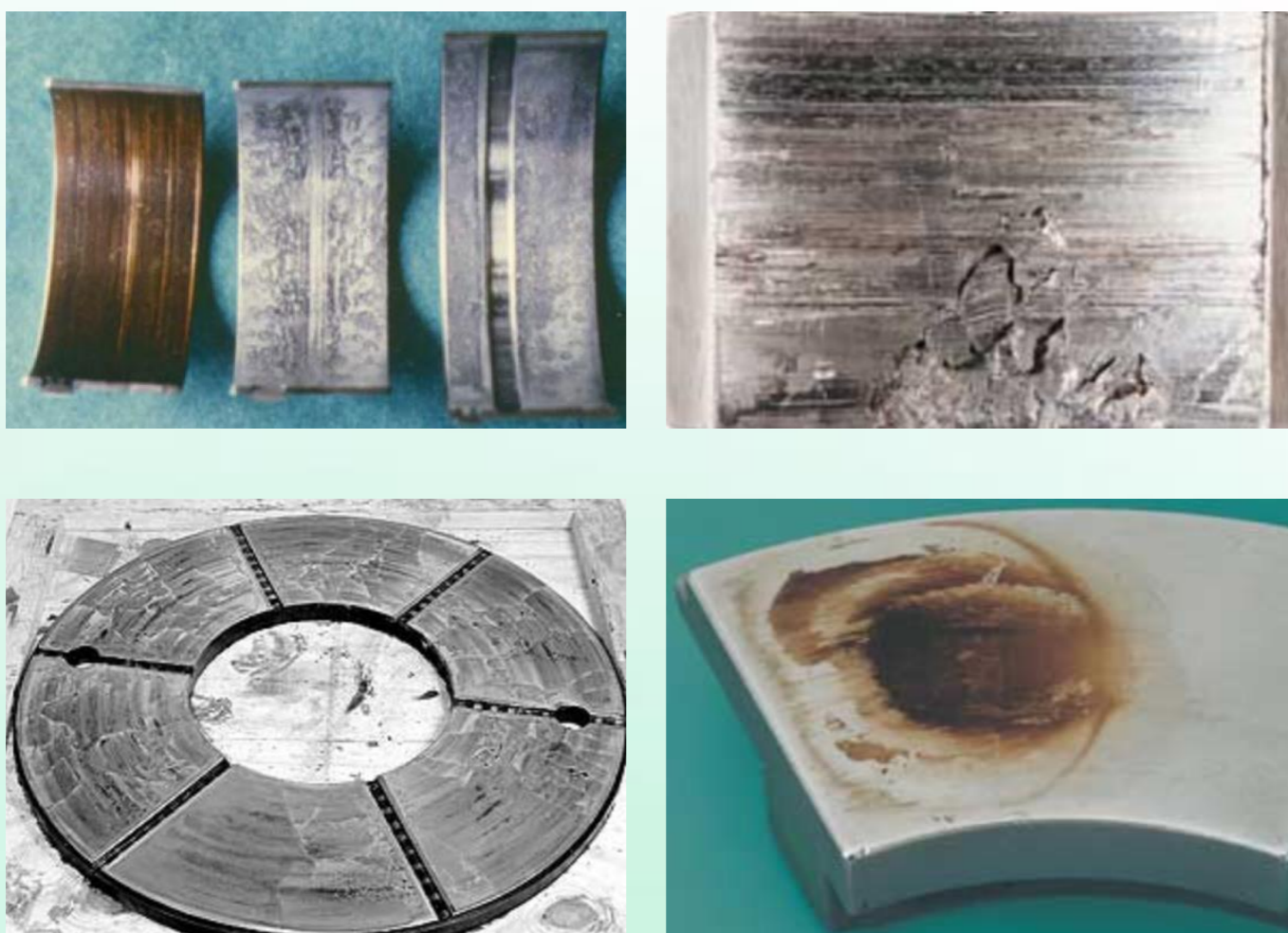

Cascade spectral display in the case of oil instability

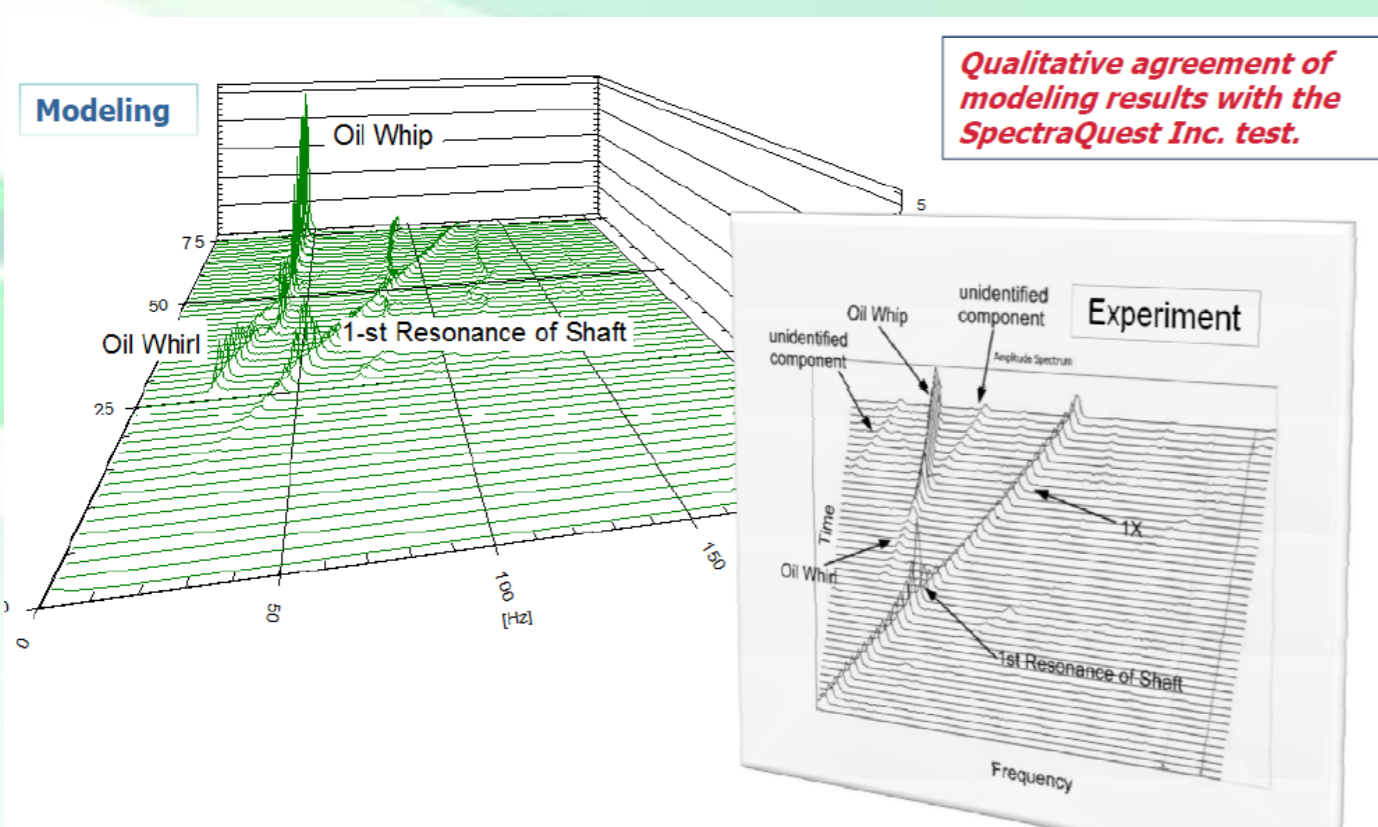

Conclusion

- Inadequate and insufficient lubrication of the plain bearing
- Analysis of the dynamic behavior of the bearing (vibration analysis)
- Analysis of the bearing temperature (thermal method)